

This literature was published years prior to the establishment of Agilent Technologies as a company independent from Hewlett-Packard and describes products or services now available through Agilent. It may also refer to products/services no longer supported by Agilent. We regret any inconvenience caused by obsolete information. For the latest information on Agilent's test and measurement products go to:

www.agilent.com/find/products

Or in the U.S., call Agilent Technologies at 1-800-452-4844 (8am-8pm EST)



Agilent Technologies

Innovating the HP Way



Noise Sources 10 MHz to 26.5 GHz

model
346A/B/C

TECHNICAL DATA JANUARY 1989

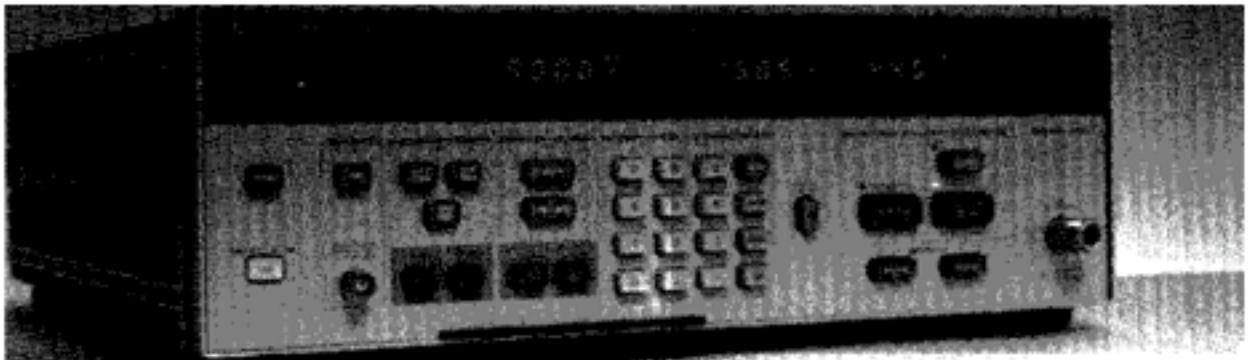

Another Step Forward in Noise Figure Accuracy

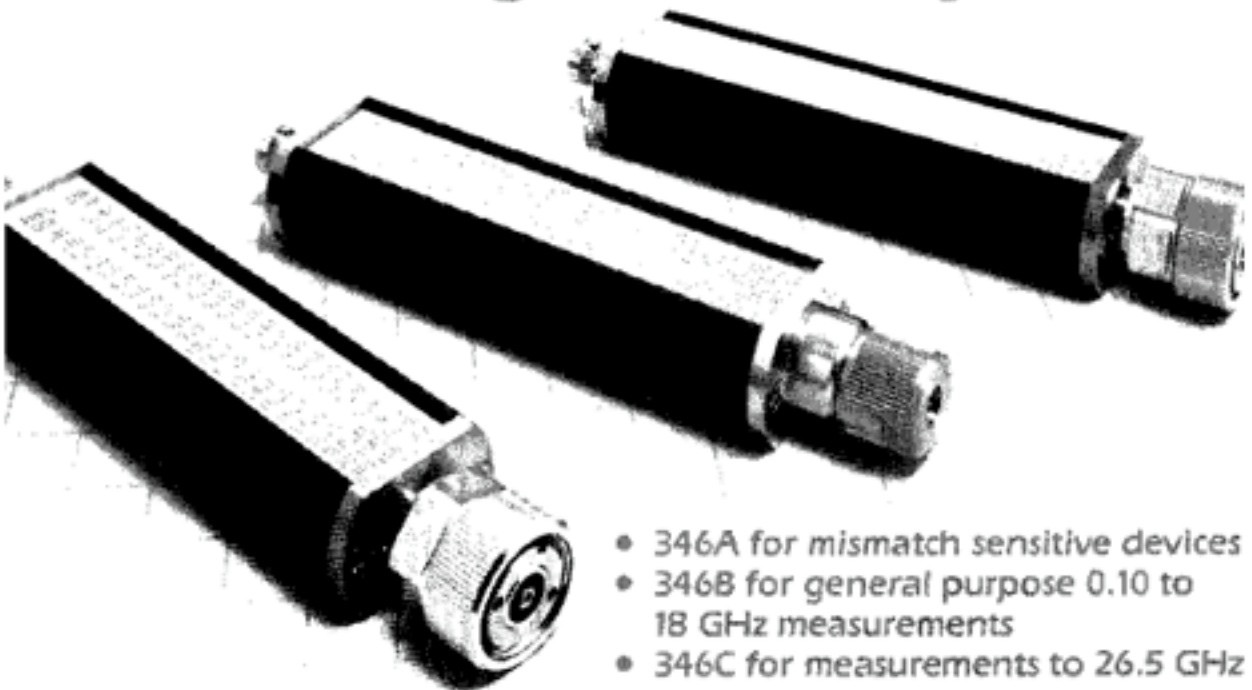

- 346A for mismatch sensitive devices
- 346B for general purpose 0.10 to 18 GHz measurements
- 346C for measurements to 26.5 GHz

And . . .

- Choice of Connectors

- Improved 3.5 mm Connector

Choose From Three Noise Sources For Your Specific Needs

346A For DUT's Without Isolators

The 346A is designed for accurately measuring devices whose gain is especially sensitive to small changes in source impedance, including most GaAsFET's. The 346A maintains the same impedance whether turned ON or OFF. This greatly reduces DUT gain changes that masquerade as DUT noise and cause noise figure measurement errors. If the DUT includes an isolator at its input, the gain is no longer overly sensitive to source impedance. Pages 6 and 7 have a detailed description of the problem solved by the 346A.

The ENR of this noise source is 6 dB from 10 MHz to 18 GHz. This means that it can be used to accurately measure noise figures up to 20 dB.

346B For General Purpose Measurements

This noise source has a choice of connectors (including the most accurate APC-7®), has a low reflection coefficient, and has an ENR of 15 dB from 10 MHz to 18 GHz. DUT's and measurement systems with noise figures up to 30 dB can be reliably measured with the 346B.

346C For K-Band Coverage

This noise source was designed to measure noise figures up to 30 dB from 10 MHz to 26.5 GHz. It has HP's new, rugged version of the APC-3.5(m) connector so that it is mode free to 26.5 GHz.

Measure Waveguide DUT's With HP 281C Precision Adapters

The 346 series of noise sources can also be used to make accurate waveguide noise figure measurements. For X, Ku, and K bands, the HP 281C series of precision waveguide/coax adapters match waveguide systems to your coaxial noise source with virtually no degradation in performance. For best results, choose APC-7 connectors on the noise source and waveguide/coax adapter where available. When using adapters, the noise source ENR should be decreased by the insertion loss of the adapter.

Precision Waveguide/Coax Adapters

Model	Frequency		Typical Insertion Loss (dB)	Connector	Waveguide; Flange
	Range (GHz)	SWR			
X281C	8.2 to 12.4	<1.05	0.08 ±0.02	APC-7	WR90;
Opt. 012				N(m)	UG-135/ U
Opt. 013				N(f)	
P281C	12.4 to 18.0	<1.06	0.10 ±0.03	APC-7	WR62;
Opt. 012				N(m)	UG-419/ U
Opt. 013				N(f)	
K281C	18.0 to 26.5	<1.07	0.13 ±0.06	APC-3.5(f)	WR42;
Opt. 012				APC-3.5(m)	UG-597/ U

® A registered trademark of Bunker Ramo Corporation.

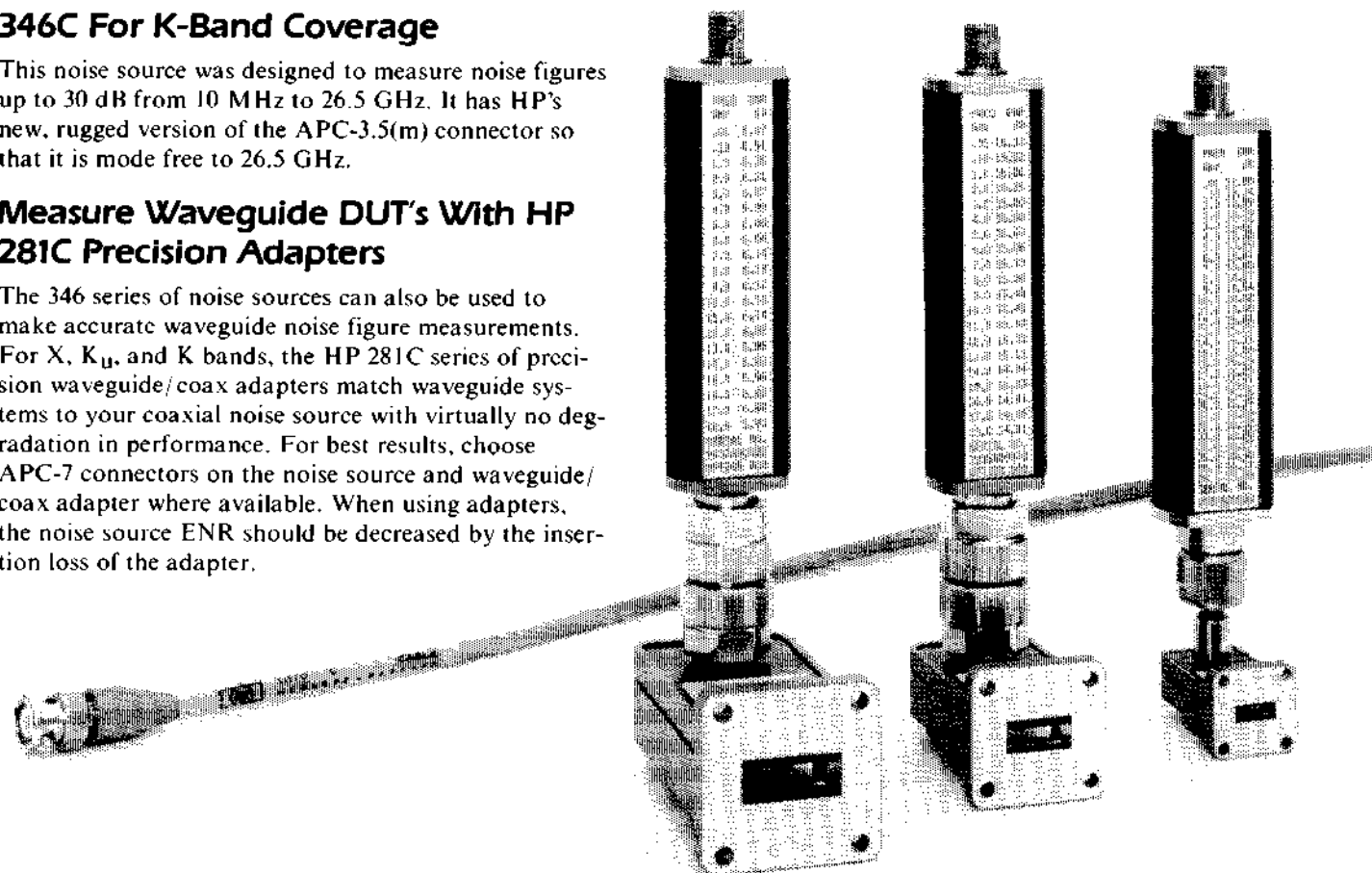

HP Hardware and Literature

Give You Complete Confidence in Noise Figure Measurements

The 346 noise source family is designed for use with HP's 8970B Noise Figure Meter. This instrument revolutionizes noise figure measurement with increased accuracy, convenience, and flexibility. Innovations include automatic error correction, reduction in equipment needs, choices of output parameters, and various modes of measurement.

The 8970/346 is enhanced by Hewlett-Packard oscilloscopes, power supplies, and local oscillators needed in most noise figure measurements setups. Computer controlled noise figure measurements are also easy with HP's totally compatible desktop computers.

All this instrumentation is backed up with a growing array of noise figure literature and noise figure seminars.

Noise Figure Literature From HP

The following literature is available from any HP sales office or write Inquiry Mgr. at 1820 Embarcadero Road, Palo Alto, CA 94303.

8970B Technical Data Sheet Lit. No. 5954-8882.

Product Note 8970A-1 "Applications and Operation of the 8670A Noise Figure Meter," Lit. No. 5952-8254.

Application Note 57-1 "Fundamentals of RF and Microwave Noise Figure Measurements," Lit. No. 5952-8255.

Programming Note 8970A/HP 85-1 "Introductory Operating Guide for the 8970A Noise Figure Meter with the HP-85 Personal Computer," Lit. No. 5952-8270.

Product Note 8350A-7 "Microwave Noise Figure Measurements using the 8350A Sweep Oscillator With the 8970A Noise Figure Meter," Lit. No. 5952-9344.



Accurate Noise Power

The output of a noise source, usually given in terms of excess noise ratio (ENR)*, must be known for accurate noise figure measurements. Any uncertainty in the ENR transfers into uncertainty of the measured noise figure, dB for dB. For each noise source, HP gives accurate and convenient ENR calibration data with . . .

- ENR data every GHz
- Data table on label
- Calibration checked periodically at nominal charge.

The 346A/B/C specifications list the uncertainty of the ENR data. Higher accuracy ENR calibration can be performed on special order in the HP Standards Laboratory at customer-selected frequencies.

*Excess noise ratio (ENR) is a measure of how much more noise power, at the specified frequency, comes from the noise source than is available from a resistor (i.e., a thermal noise source) at 290K (16.8°C). Thus an ENR of 15.14 dB means the noise source output is 15.14 dB larger than the noise power available from a resistor at 290K (equivalent to a resistor at 9761 K).



The Importance of Noise Source Reflection Coefficient

Two aspects of reflection coefficient are important:

(1) A non-zero reflection coefficient contributes to re-reflections between the DUT and the source. The re-reflections cause uncertainty in the noise power emerging from the source. The measured noise figure, furthermore, refers to the actual noise source impedance rather than the desired 50Ω value. The low reflection coefficient of HP noise sources usually keeps this uncertainty under 0.1 dB.

(2) The *change* in reflection coefficient between OFF and ON can cause DUT gain variations which, in turn, cause noise figure errors. This problem, thoroughly discussed on pages 6 and 7, is effectively eliminated by the 346A, whose complex reflection coefficient *change* is specified to be less than 0.01.

HP reflection coefficient performance does not stop there. Each noise source comes with a calibration sheet showing the magnitude and angle of the reflection coefficient for both the ON and OFF conditions. You can use that data, for example, to calculate the true noise figure accuracy limits when using your HP noise source. The limits will often be about 1/3 of what they would be if specification limits were used instead of measured reflection coefficients.

HEWLETT PACKARD CALIBRATION REPORT

MODEL 346B DPT 002		SERIAL NO: 1935A00078			
DATE: JULY 20 1983		TECHNICIAN: 2267			
FREQUENCY MHZ	ENR dB	REFL - ON MAG	REFL - ON ANG	REFL - OFF MAG	REFL - OFF ANG
10.00	15.33	.045	-132.0	.032	-71.0
100.00	15.52	.036	171.2	.009	-26.9
1000.00	15.26	.041	36.1	.000	161.5
2000.00	15.15	.042	-83.7	.029	-0.4
3000.00	15.00	.022	161.5	.042	-123.6
4000.00	15.00	.015	-84.2	.026	129.0
5000.00	15.03	.046	159.9	.013	-167.2
6000.00	15.06	.062	57.5	.051	94.0
7000.00	15.10	.054	-43.8	.069	-13.3
8000.00	15.26	.032	-131.9	.065	-120.1
9000.00	15.40	.016	-173.4	.039	130.2
10000.00	15.46	.027	132.6	.007	-11.1
11000.00	15.42	.033	42.9	.027	107.4
12000.00	15.33	.030	-33.7	.053	-2.2
13000.00	15.19	.033	-81.5	.060	-99.1
14000.00	14.94	.050	-147.0	.043	176.9
15000.00	15.03	.054	124.2	.026	116.7
16000.00	14.91	.046	10.7	.029	53.6
17000.00	14.95	.036	-84.6	.040	-42.6
18000.00	14.91	.024	-145.9	.049	-137.1

Connector Recommendations

For long connector life and stable noise output, HP recommends that you use the APC-7 connector (346A/B Option 002) whenever possible because. . .

- Connector repeatability is so much better than for other connectors that ENR can be proven stable with time.
 - Four 346B's with APC-7 connectors were measured at HP to be stable to <0.04 dB over 2-1/2 years.
 - An independent standards laboratory monitored two 346B Option 002's to have <0.01 dB variation in ENR over one year.
- Connector wear is minimal in ordinary use.
 - Mating surfaces are visible so damage can often be easily observed.
 - APC-7 noise sources returned for periodic recalibration seldom have connector problems.
- The sexless connector reduces compatibility problems and simplifies loss measurement of adapters.
- The recommended torque wrench is available from HP (see ordering information on the last page).
- If your DUT has SMA connectors for use below 18 GHz, HP still recommends the Option 002 with an APC-7/ APC-3.5 adapter (included in ordering information on the last page).
 - The adapter loss and reflections slightly increase the noise figure measurement uncertainty (estimated to be <0.05 dB), but when the adapter wears out it can be replaced without recalibrating the noise source ENR.
- The APC-3.5 connector was designed for instrumentation applications requiring long life, low reflection coefficient, and mating with SMA connectors.
 - It has a life of over 1000 connections when
 - (1) it is properly torqued, and
 - (2) when tightening, only the connector is turned and not the body of the components being connected (body rotation causes rubbing and rapid wear of the conducting surfaces and possible disassembly of the connector), and
 - (3) connectors are cleaned after every 10 connections, and
 - (4) the mating connector is a healthy APC-3.5 connector.
 - It has a life of under 200 connections when used casually. This includes . . .
 - (1) estimating the torque with an ordinary wrench.
 - (2) occasional, accidental final tightening and loosening by applying torque to the noise source body,
 - (3) frequent mating with an over-used SMA connector (common for mixers used in down converters for noise figure measurements).
- Now HP noise sources have an improved APC-3.5 connector.
 - The connector nut is larger to allow easier tightening without applying torque to the body.
 - The connector is considerably stronger.
 - The recommended torque wrench is available from HP (see ordering information on the last page).

Recommended Torque Wrenches

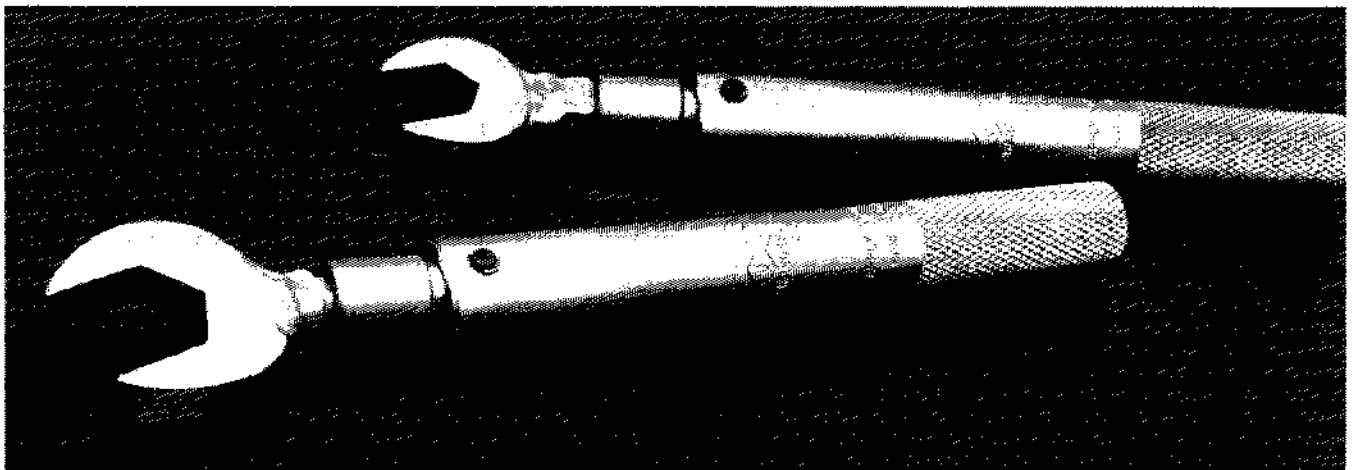

How Gain Changes Cause Noise Figure Errors

To show the problem solved by the 346A, consider a GaAsFET amplifier stage whose noise characteristics are already known. The noise figures that would be measured by (1) a standard noise source and (2) the 346A are calculated and compared to the known noise figure.

Consider the GaAsFET to have the scattering matrix

$$S = \begin{bmatrix} 0.89/-88 & 0.037/33 \\ 0.5037/113 & 0.787/-30 \end{bmatrix}$$

and $F_{\min} = 1.1$ dB, $\Gamma_{\text{opt}} = 0.75/86$, and $R_n = 45\Omega$ (this is manufacturer supplied data for a commercial GaAsFET at 4 GHz). If the GaAsFET is preceded by a lossless matching network with $S_{11} = S_{22} = 0.75/86$, a minimum noise figure of 1.1 dB will occur for a 50Ω source. Loci of constant noise figure and available gain are plotted on the Γ_s plane. The GaAsFET is potentially unstable.

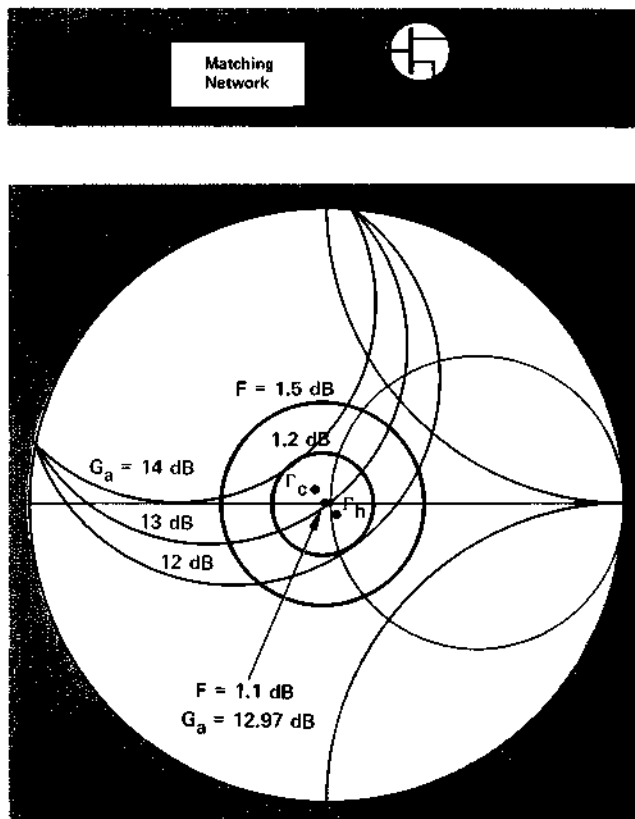

Noise figure and available gain characteristic of an amplifier stage consisting of the matching network and GaAsFET described in the text.

Ordinary Noise Source

First consider an ordinary noise source with $\Gamma_h = 0.05/-45$ and $\Gamma_c = 0.05/135$ (plotted on the Smith chart) for a total $\Delta\Gamma$ of 0.10 between Γ_h and Γ_c . (This corresponds to a SWR of only 1.1, which is well within the specifications of noise sources. It also corresponds to the largest observed change in reflection coefficient from among more than five hundred 346B noise sources.) The actual noise figure of the DUT at those reflections is 1.11 dB, but the available gain is 12.68 dB and 13.26 dB respectively. The noise figure measurement process calculates noise figure from measured Y factor*. The Y factor relates to T_e , effective input noise temperature, by

$$Y = \frac{G_a (T_h + T_e)}{G_a (T_c + T_e)}$$

where G_a is the available gain, and T_h and T_c are the hot and cold noise temperatures of the source. T_e is 83.6K for 1.1 dB noise figure and 84.5K for 1.11 dB. For non-changing gain, the G_a 's cancel and the measured Y factor is proper. For this example, however, the changing gain causes the usual Y factor to be in error by the gain change of 0.58 dB. The corresponding T_e is 140K or a noise figure of 1.71 dB, an error of 0.61 dB. If Γ_h and Γ_c were reversed, the measured noise figure would be 0.51 dB, an error of -0.59 dB. These errors are much larger than what the noise figure contours on the Smith chart indicate.

If the reflection coefficient were to change along a constant gain circle, e.g., from $0.05/45$ to $0.05/135$, there is only 0.06 change in gain and 0.06 dB error in noise figure. This shows the phase relationships are important.

346A Noise Source

Now consider the 346A noise source, which solves the gain change problem by including an extra internal 10 dB attenuator. This means the change in reflection coefficient is 20 dB lower (i.e., 1/10 the change) than the usual source so that the maximum $\Delta\Gamma = 0.01$. For $\Gamma_h = 0.05/-45$ and $\Gamma_c = 0.04/-45$, the gain varies by only 0.06 dB, the Y factor error is 0.06 dB, and the measured noise figure is 1.16 dB — an error of only 0.06 dB.

*HP Application Note 57-1 defines and discusses noise concepts and terms.

Should You Choose the 346A?

A very good indication is to perform the following steps for the setup shown.

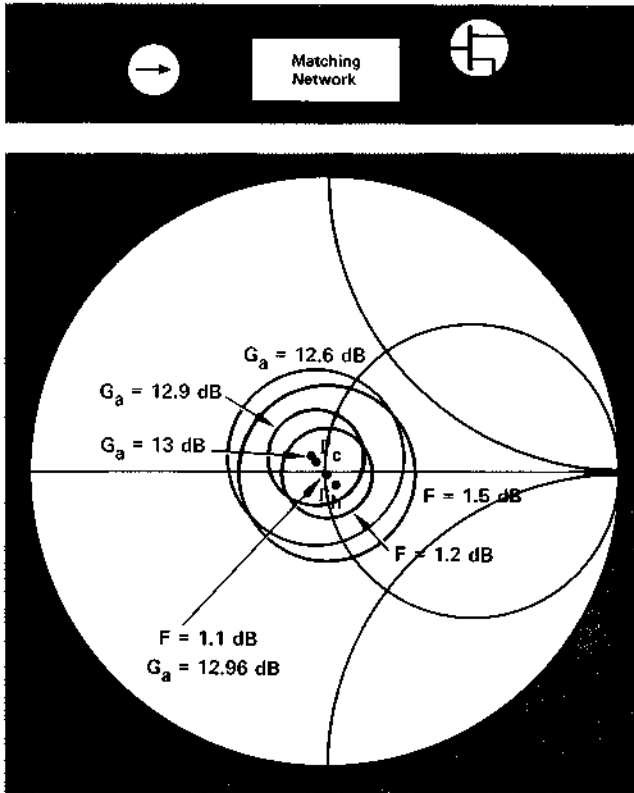

Noise figure and available gain characteristic of a 20 dB isolator, matching network, and GaAsFET.

DUT's With Internal Isolators Already OK

Devices that have isolators at the input do not have this problem because the isolator forces the available gain to have about the same sensitivity to source impedance as noise figure. The same matching network and GaAsFET preceded by an isolator with only 20 dB isolation has the gain and noise figure loci shown. (The maximum available gain and minimum noise figure occur for slightly different source impedances. Infinite isolation would cause the two points and the constant gain and noise figure circles to be superimposed.) A $\Gamma_h = 0.05 \angle -45^\circ$ and $\Gamma_c = 0.05 \angle 135^\circ$ cause a decrease in gain of only 0.06 dB. The measured noise figure is 1.17 dB for an error of only 0.06 dB. This shows that, with the isolator, the 346A Noise Source is not especially needed.

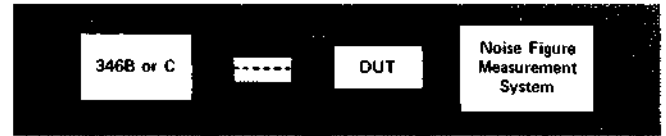

1. Measure noise figure F_1 with a direct connection from noise source to DUT.
 2. Measure noise figure F_2 with airline #1 between the noise source and DUT (you can probably use the APC-7 airlines from the calibration kit of a vector network analyzer).
 3. Measure noise figure F_3 with airline #2 between the noise source and the DUT.
 4. Measure noise figure F_4 with both airlines between the noise source and DUT.
 5. If F_1 , F_2 , F_3 , and F_4 differ by more than about 0.1 dB, you probably have mismatch problems that would be solved by the 346A. Step 6 verifies the problem.
 6. Add a 10 dB attenuator to the 346B or 346C and perform steps 1 to 5 again. Now if the values of F_1 , F_2 , F_3 , and F_4 are much closer together, (although different than the first measurements because of added ENR uncertainty) the 346A is definitely needed.
- You probably need the 346A if your DUT has a GaAsFET for the input stage without an isolator.
 - You probably do not need the 346A if your DUT has an isolator at the input.
 - A 346B or C noise source with an isolator attached is not as effective as the 346A because . . .
 - (a) The ENR uncertainty is increased by the loss of the isolator and by re-reflections between the source and isolator.
 - (b) Isolators do not normally have instrumentation type connectors designed for frequent, accurate, and repeatable connections.
 - (c) Isolators are not always available and they are somewhat limited in frequency range.

346A/B/C Noise Source Specifications

Specifications describe the instrument's warranted performance. Supplemental characteristics are intended to provide information useful in applying the instrument by giving typical, but not warranted, performance parameters.

ENR accuracy: calibrations at cardinal frequencies are printed on each noise source and on a separate report shipped with each 346 Noise Source to the accuracy shown in the following table:

Frequency (GHz)	Worst Case Uncertainty (dB)	Root-Sum-of-Squares Uncertainty (dB)
346A		
0.01 to 1	0.25	0.08
2 to 18	0.31	0.14
346B/C		
0.01 to 1	0.24	0.09
2 to 18	0.28	0.13
19 to 21	0.41	0.13
22 to 26.5	0.47	0.14

ENR calibrations are traceable to the U.S. National Bureau of Standards (NBS) from 2 GHz to 18 GHz. At frequencies where NBS does not offer ENR measurement service, calibrations are referenced to physical hot and cold loads.

Frequency range: 10 MHz to 18 GHz for 346A and 346B; 10 MHz to 26.5 GHz for 346C.

Excess noise ratio (ENR) range: Calibrated values at cardinal frequencies printed on label. Range of value is 5 to 7 dB for 346A, 14 to 16 dB for 346B, and 12 to 16 dB (10 MHz to 12 GHz) and 14 to 17 dB (12 to 26.5 GHz) for 346C.

Maximum SWR (reflection coefficient) for source ON and source OFF (50 ohm reference impedance):

346A/B: 10 to 30 MHz — 1.3 (0.13)
30 to 5000 MHz — 1.15 (0.07)
5 to 18 GHz — 1.25 (0.11)
346C: 10 MHz to 18 GHz — 1.25 (0.11)
18 to 26.5 GHz — 1.35 (0.15).

Maximum change in complex reflection coefficient between source ON and source OFF at all frequencies for 346A only: 0.01.

Power required: (automatically furnished by the 8970B Noise Figure Meter) $28 \pm 1V$.

346A/B: 60 mA peak, 30 mA average for source ON.
346C: 45 mA.

Operating temperature: 0 to 55°C.

Connectors: bias: BNC(f); noise output: APC-3.5(m) — also mates with female SMA connectors. See ordering information for other connector styles.

Maximum reverse power: 1W.

Dimensions: 140 x 21 x 31 mm (5.5 x 0.8 x 1.2 in.).

Net weight: 0.1 kg (3.5 oz.).

Shipping weight: 0.5 kg (1 lb).

Supplemental Characteristics

ENR variation with temperature: <0.01 dB/°C for 30 MHz to 26.5 GHz.

ENR variation with voltage: internal current regulator for <0.02 dB variation for $28 \pm 1V$.

Switching speed: for repetitive operation (in previous state for less than 5 seconds), turn-on: $<20 \mu s$; turn-off: $<80 \mu s$. For single shot operation (in previous state more than 5 seconds), turn-on: <3 ms; turn-off: $<80 \mu s$.

Ordering Information

346A Noise Source

346B Noise Source

346C Noise Source

Option 001 (346A/B only):

Type N(m) noise output connector

Option 002 (346A/B only):

APC-7 noise output connector

Option 004 (346A/B only):

Type N(f) noise output connector

Recommended models are:

346B Option 002 for general purpose applications to 18 GHz with adapters listed below as necessary.

346A Option 002 for mismatch sensitive devices to 18 GHz with adapters listed below as necessary.

346C for applications to 26.5 GHz.

Accessories

X281C APC-7 to WR 90 Adapter

P281C APC-7 to WR 62 Adapter

K281C APC-3.5 to WR 42 Adapter

11524A APC-7 to N(m) Adapter

11525A APC-7 to N(f) Adapter

1250-1746 APC-3.5(m) to APC-7 Adapter

1250-1747 APC-3.5(f) to APC-7 Adapter

5060-0343 3/4" Torque Wrench (APC-7)

5060-0344 9/16" Torque Wrench (for the new standard 346 with larger APC-3.5 nut)

Data Subject to Change.

For more information, call your local HP sales office listed in the telephone directory white pages. Ask for the Electronic Instruments Department, or write to Hewlett-Packard: United States: Hewlett-Packard Company, 4 Choke Cherry Road, Rockville, MD 20850 (301) 670-4300; Italy: Hewlett-Packard Italiana S.p.A., Via G. di Vittorio, 9 20063 Cernusco Sul Naviglio (MI) Milano 02/923691; European Multi Country Region: Hewlett-Packard S.A., Route du Nant d'Avril 150 1217 Meyrin 2 - Geneva Switzerland (41) 22/83 81 11.